

# Montageanleitung/Assembly Instruction

Art. Nr./Item No. 81199

DE: WICHTIG: BITTE SORGFÄLTIG LESEN UND FÜR KÜNFTIGE RÜCKFRAGEN AUFBEWAHREN.  
EN IMPORTANT; KEEP FOR FUTURE REFERENCE: READ CAREFULLY

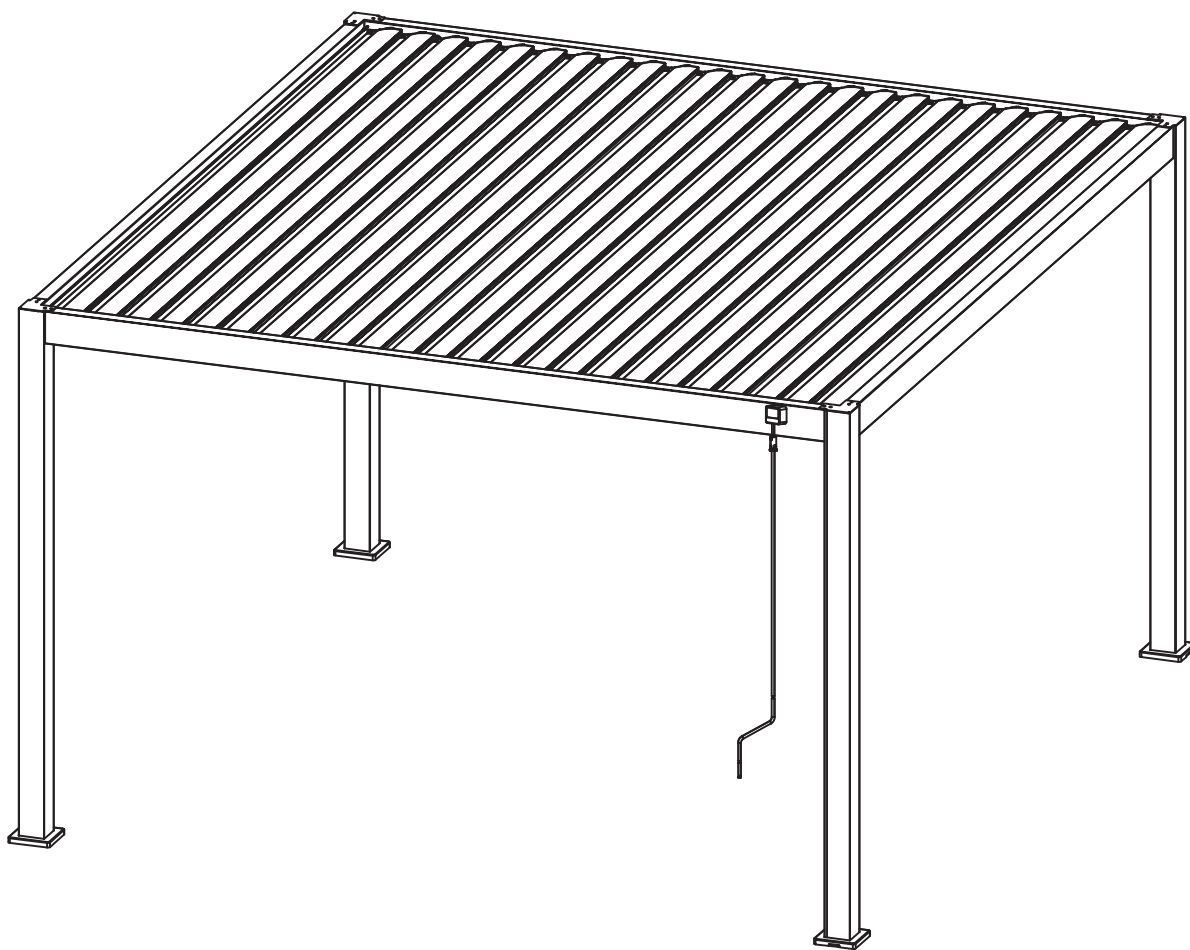











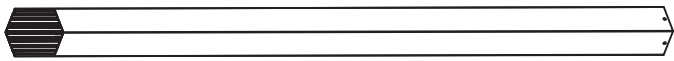

## 4x4M



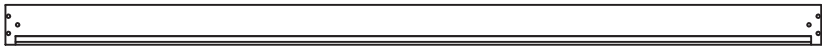

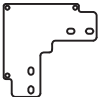
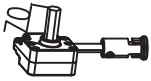

Außenmöbel für die Verwendung im Wohnbereich. Outdoor furniture for domestic use.

MB Outdoor GmbH, Lüttinger Str. 25, DE-46509 Xanten, Germany

1

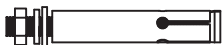
OUTFLEX®

A			(X4)
B			(X1)
C			(X1)
D			(X2)
E			(X24)
F			(X4)
G			(X4)
H			(X4)
J			(X1)
K			(X1)
L			(X1)

1#		M6*16	(X49+2)
2#		M6*20	(X48+2)
4#		M8	(X16)
5#		$\Phi 16 * \Phi 7 * 1$	(X1)
		6mm	(X1)
		4mm	(X1)
		4mm	(X1)

1

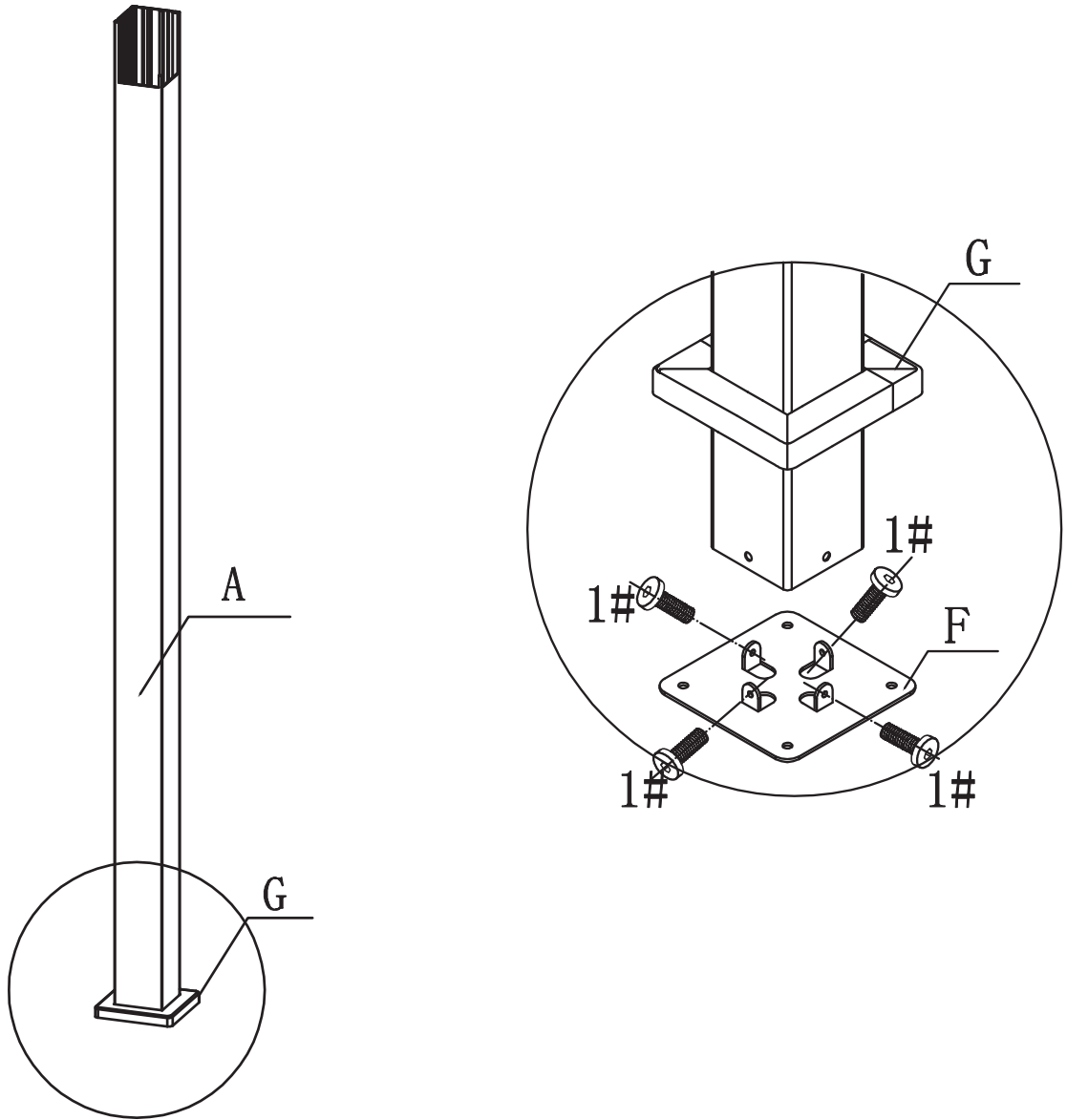

A	4		F	4	
1#	16		G	4	

Außenmöbel für die Verwendung im Wohnbereich. Outdoor furniture for domestic use.

MB Outdoor GmbH, Lüttinger Str. 25, DE-46509 Xanten, Germany

2

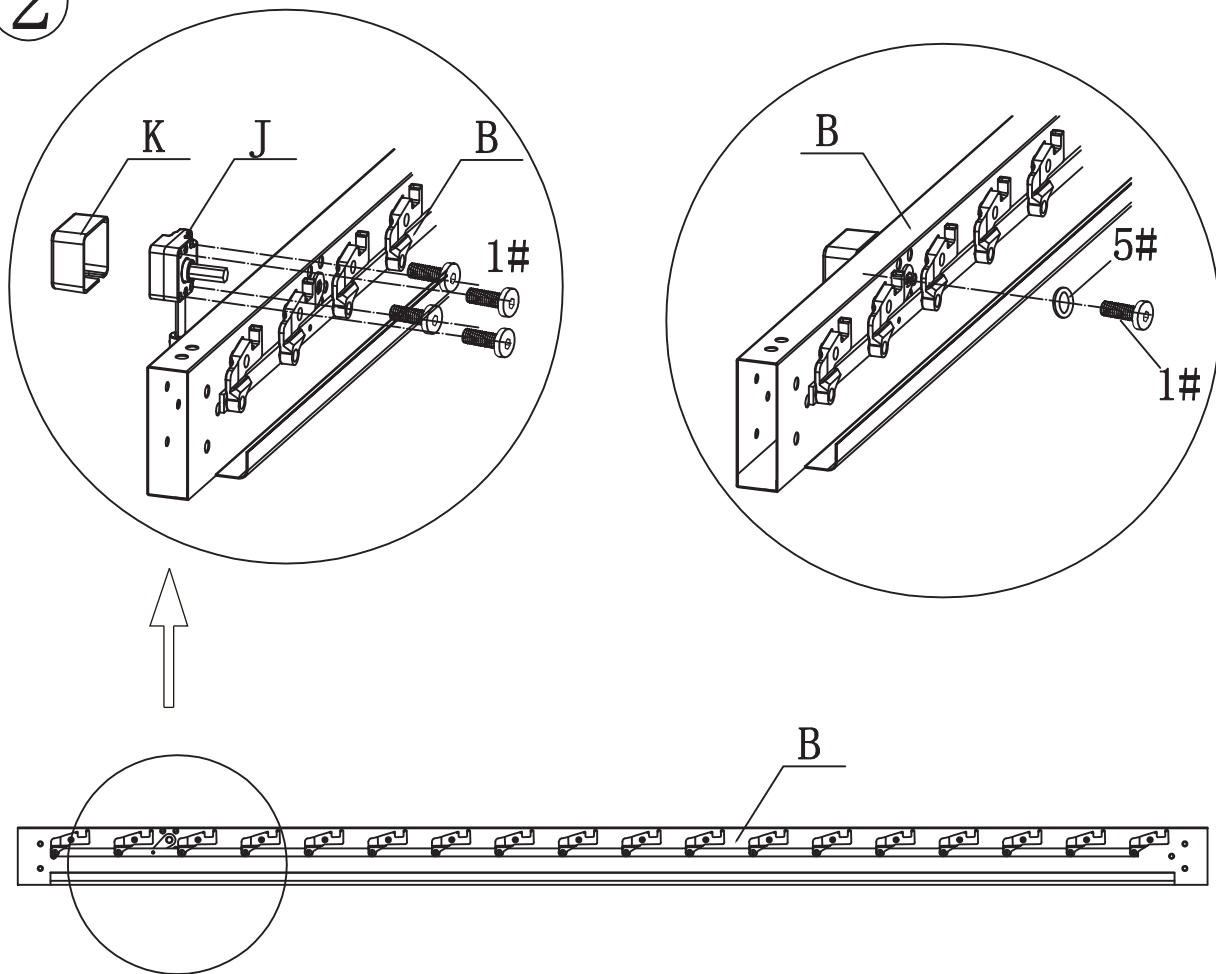

**Note:**

First, take off the #1 screw and #5 washer that are already attached to the crank.

Then, install the crank to B beam.

Finally, adjust the transmission device so it's in the right position. Then use the #1 screw and #5 washer to lock the B beam and crank.

**Anmerkung:**

Entfernen Sie zunächst die Schraube #1 und Unterlegscheibe #5 die bereits mit der Kurbel verbunden sind

Montieren Sie dann die Kurbel an Stange B

Stellen Sie abschließend das Getriebe in die richtige Position ein. Anschließend fixieren Sie den B-Träger mit der Schraube #1 und der Unterlegscheibe #5 und kurbeln ihn an

B	1				
J	1		K	1	
1#	5		5#	1	

3

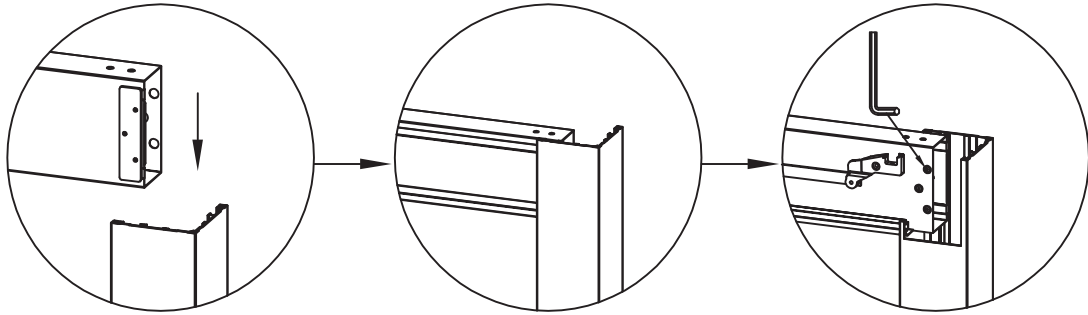

All M8 screws come pre-installed on the beam. Before attaching the beam to the column, loosen the M8 screws. Once the beam and column are connected, tighten the M8 screws again.

Alle M8-Schrauben sind am Träger vormontiert. Lösen Sie die M8-Schrauben, bevor Sie den Träger an der Stütze befestigen. Sobald Träger und Stütze verbunden sind, ziehen Sie die M8-Schrauben wieder fest

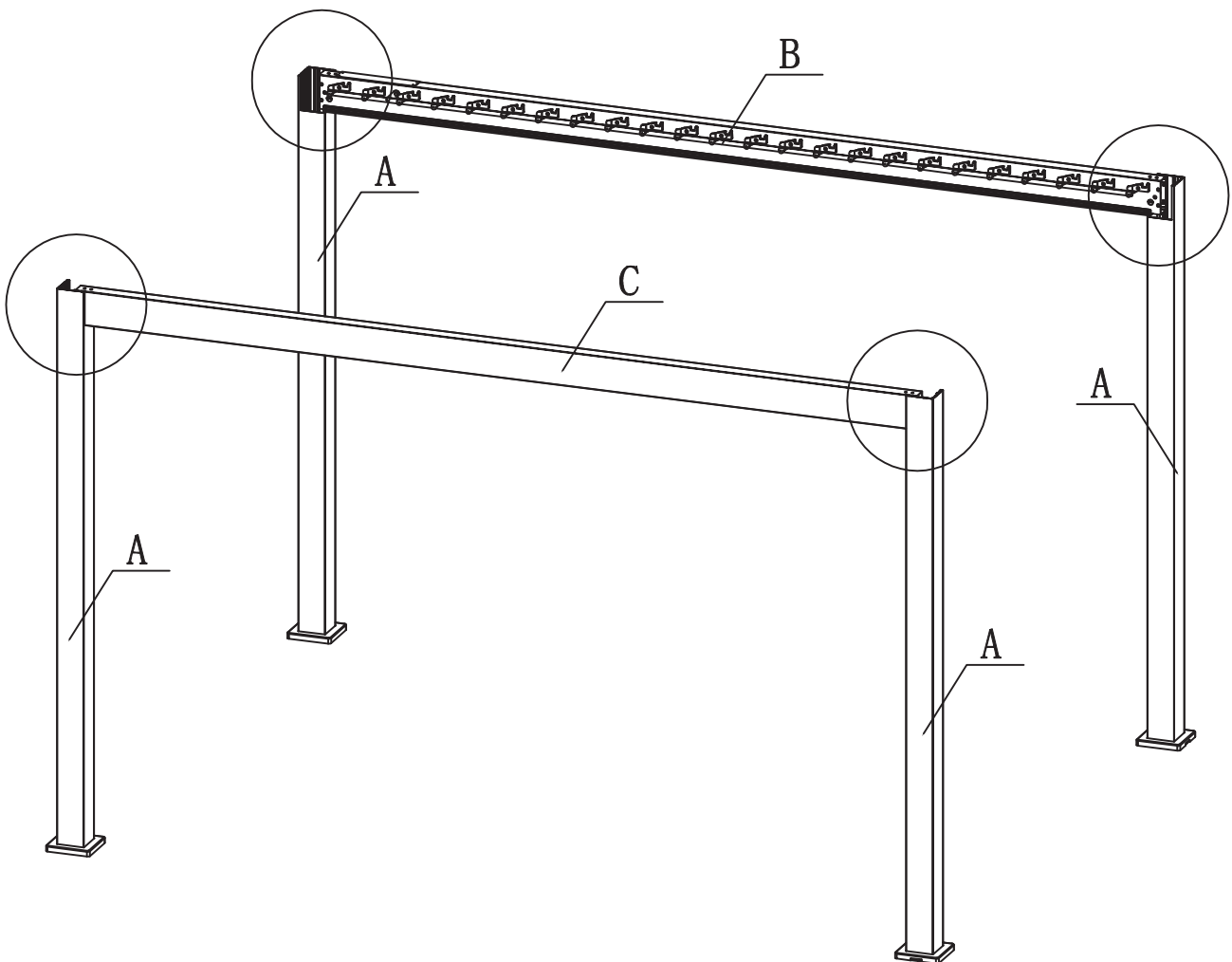

B	1	
C	1	

④

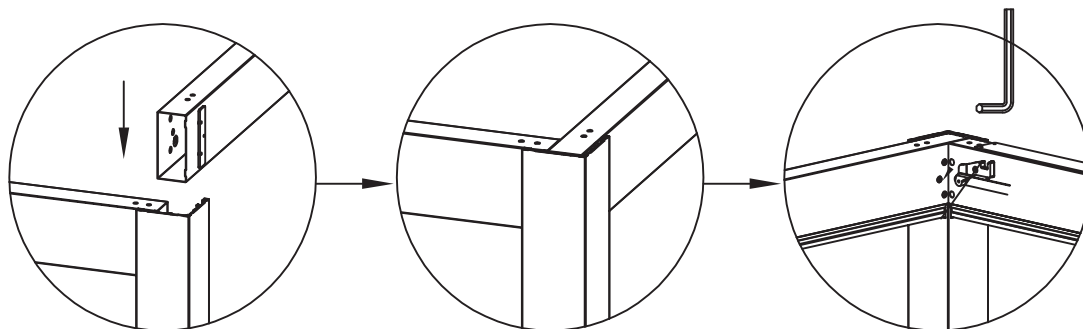

All M8 screws come pre-installed on the beam. Before attaching the beam to the column, loosen the M8 screws. Once the beam and column are connected, tighten the M8 screws again.

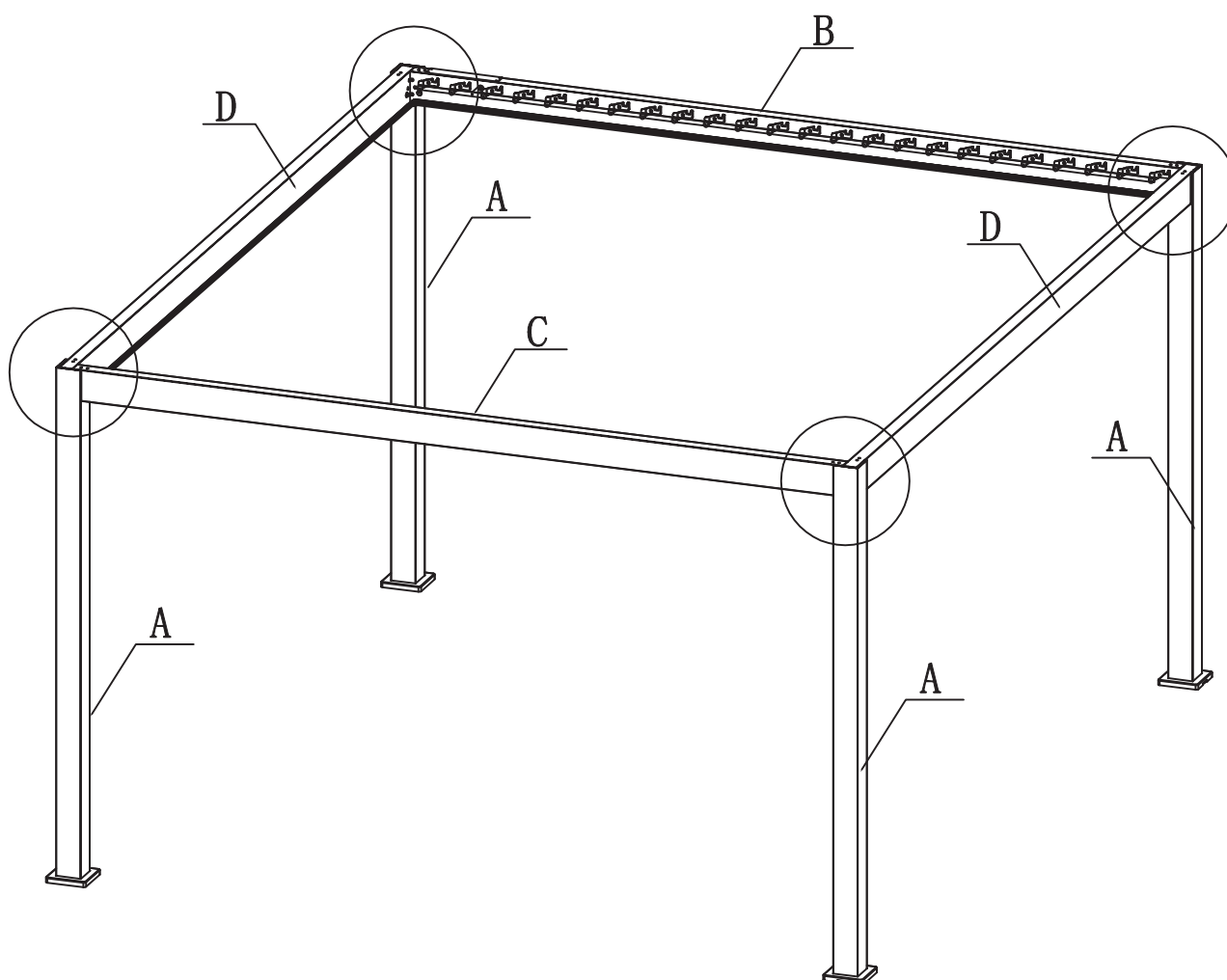

Alle M8-Schrauben sind am Träger vormontiert. Lösen Sie die M8-Schrauben, bevor Sie den Träger an der Stütze befestigen. Sobald Träger und Stütze verbunden sind, ziehen Sie die M8-Schrauben wieder fest

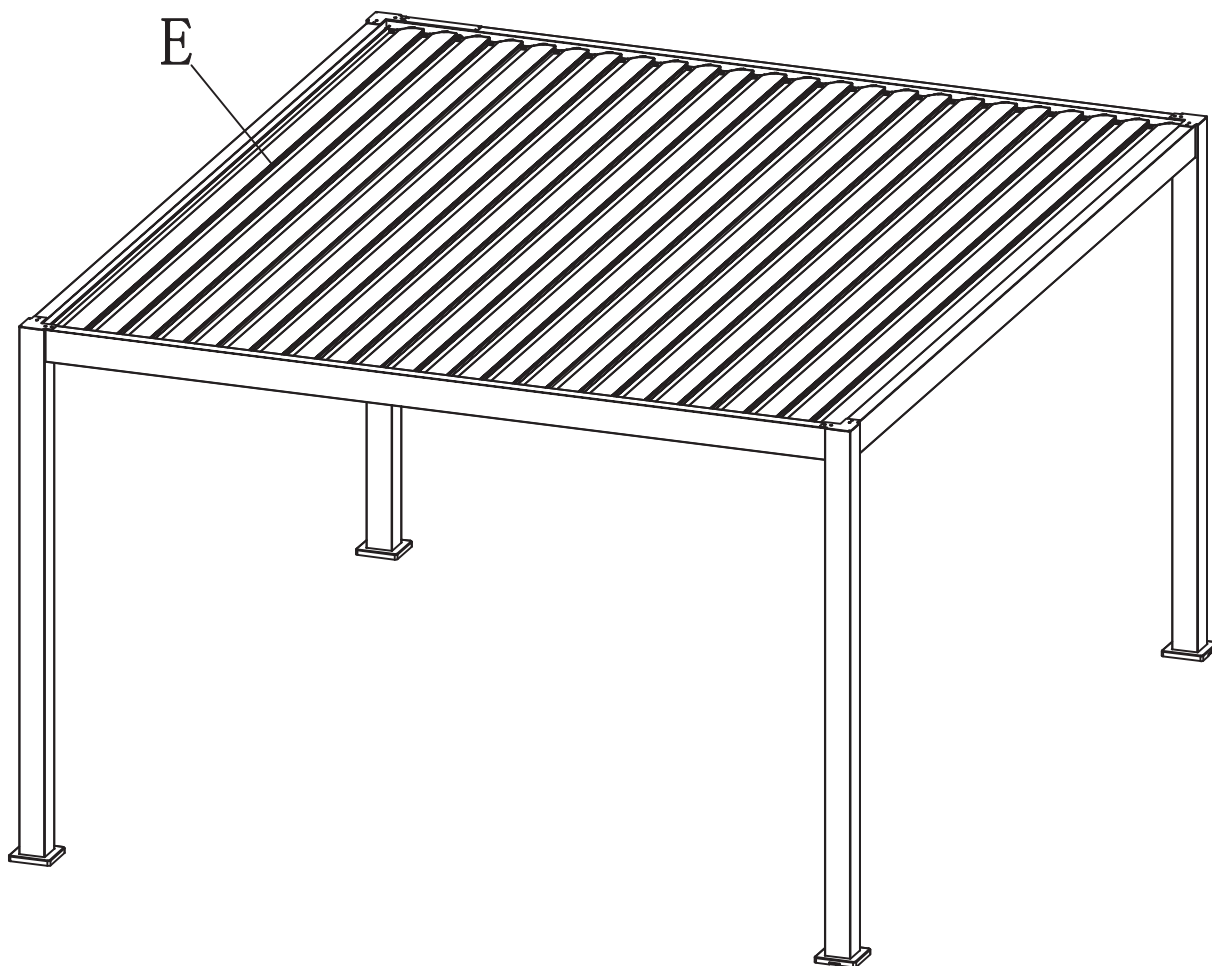
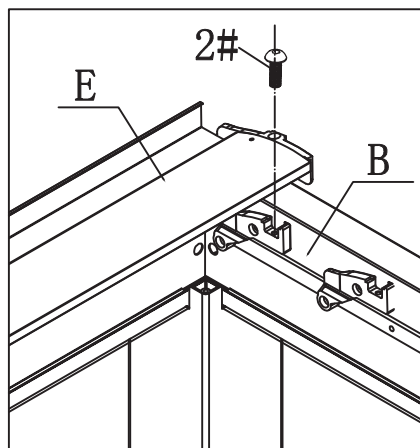
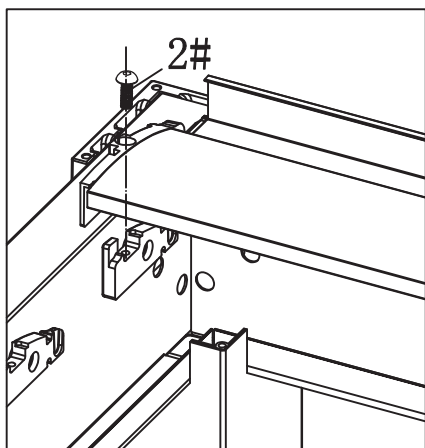

D	2	
---	---	--

5



E	24	
2#	48	

Außenmöbel für die Verwendung im Wohnbereich. Outdoor furniture for domestic use.

MB Outdoor GmbH, Lüttinger Str. 25, DE-46509 Xanten, Germany

6

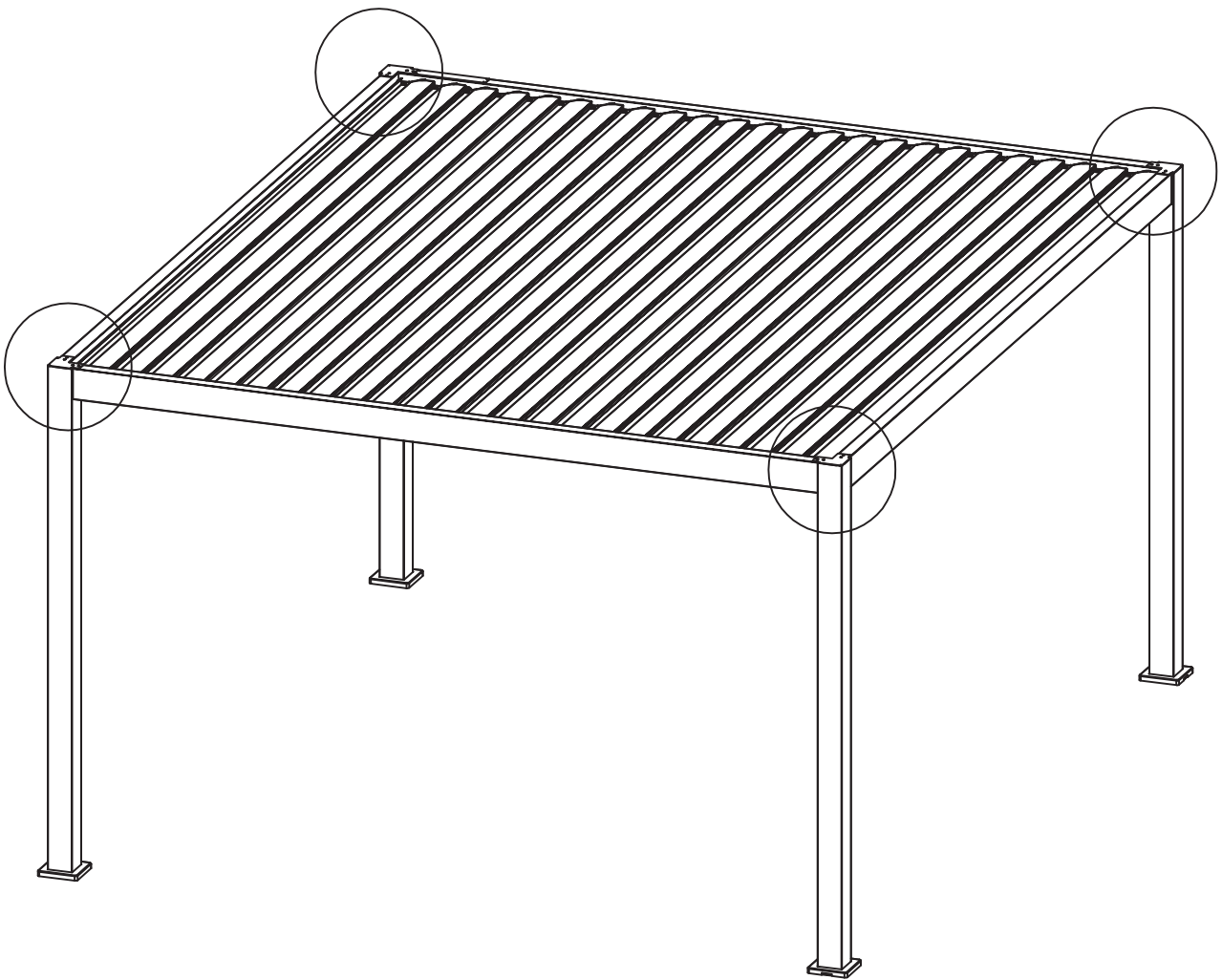
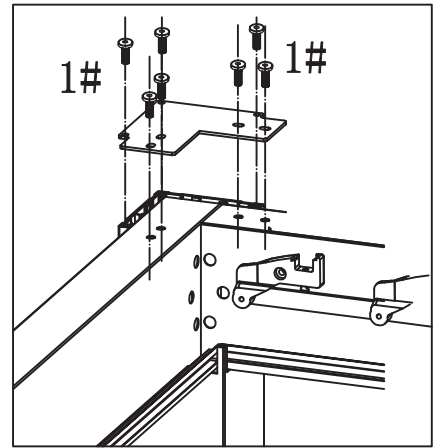

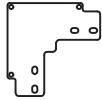
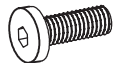
H	4	
1#	28	

Außenmöbel für die Verwendung im Wohnbereich. Outdoor furniture for domestic use.

7

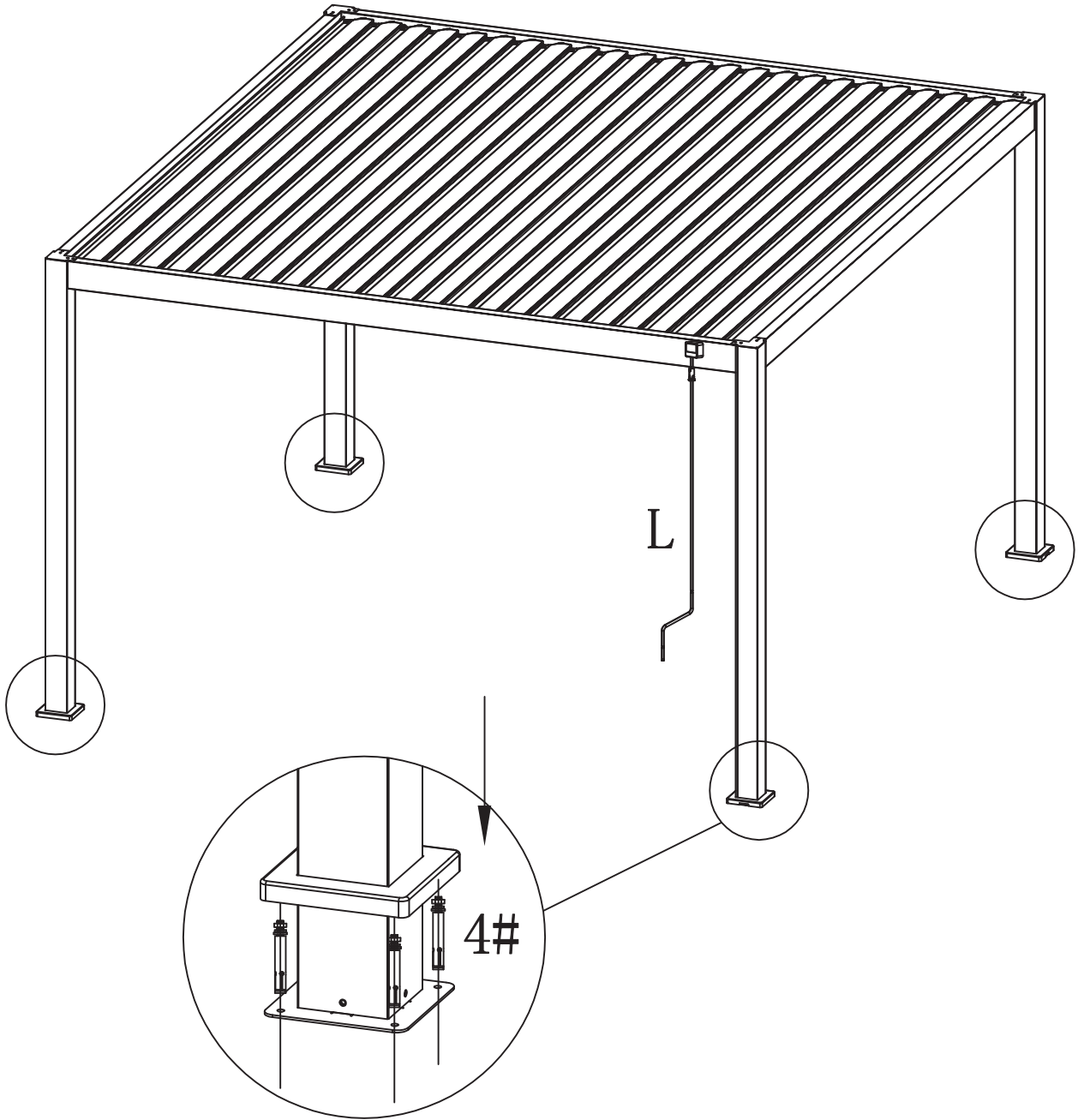

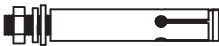
L	1	
4#	16	 M8

Außenmöbel für die Verwendung im Wohnbereich. Outdoor furniture for domestic use.